

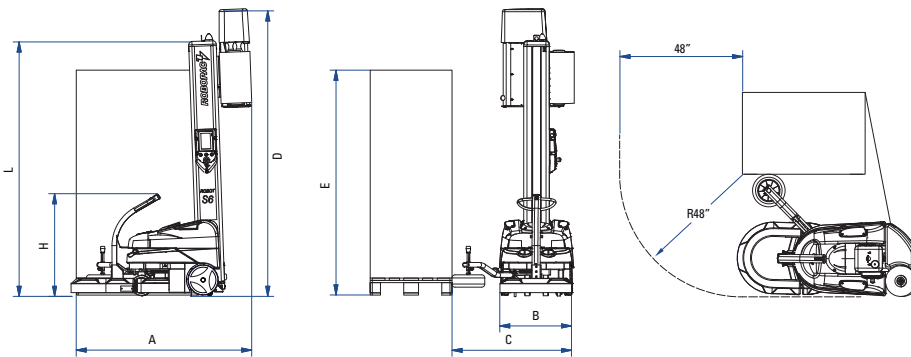

Robot S6

SELF-PROPELLED ROBOT FOR STRETCH WRAPPING

- ▶ ONBOARD BATTERY CHARGER 120 V SINGLE PHASE
- ▶ ACTIVE EMERGENCY STOP BUMPER
- ▶ "QLS" (QUICK LOAD SYSTEM) FOR EASY AND QUICK FILM LOADING
- ▶ IDLE WHEEL ENSURES PORTABILITY WITHOUT POWER
- ▶ WHEEL HEIGHT ADJUSTMENT
- ▶ NEW COLOR TOUCH SCREEN CONTROL PANEL
- ▶ AUTOMATIC FILM CUTTING DEVICE



TECHNICAL FEATURES

MACHINE	ROBOT S6 PVS	
Industrial duty batteries	12 V	(n.)
Rotation speed	35-50	(ft/min)
Upward-downward carriage speed	up to 260	(ft/min)
Power supply	115V single phase, 20 amp, 60Hz	(V)
Rear and both sides forklifting	STD	

CHARACTERISTICS OF THE PRODUCT TO BE WRAPPED

Minimum dimensions	24"x24"	(in)
Maximum useful height	110 or 86	(in)
Minimum load weight	200	(lbs)

FILM FEATURES

Max. external diameter	12	(in)
Internal diameter	3	(in)
Film thickness	39-120	(gauge)
Film height	STD 20"carriage - OPT 30"carriage	(in)
Max. spool weight	44	(lbs)

PROGRAMMING (Standard, Partial Cube, Cube Technology)

12 unique wrapping recipes can be programmed from the color touch screen	STD
Dark load height sensing by photocell	STD

(*)Possibility of stretch wrapping the half and quarter pallet
 (**)Under defined wrapping cycles and pallet sizes
 (***) According to film quality
 T.I. Top Inside

**Smart Solutions.
 Even Smarter Machines.**
 Innovation | Reliability | Service